

544



ADW600 Multi-circuit power
metering module

Installation and operation instruction
V1.1

ACREL Co.,Ltd

Declaration

The copyright is the property of Acrel. Any information in any paragraph or section cannot be extracted, copied or otherwise reproduced or propagated. Otherwise offenders shall take all consequences.

All rights are reserved.

Acrel reserves the right to modify the product specifications herein without notification. Please consult the local agent about the latest specifications before placing a purchase order.

Manual revision record

Data	Old	New	Change
2024/12/2		V1.0	1.First version
2025/4/21		V1.1	1.Add the description of the main module 2.Add the address of the module type

Content

1. General.....	1
2. Type and Function description.....	1
1) ADW600 Multi-circuit power metering module naming rules.....	1
2) ADW600 Functions.....	1
3. Technical parameter.....	2
3.1 Electrical Characteristics.....	2
3.2 Environmental Conditions.....	2
4. Dimension drawings and Installing.....	3
4.1 Dimension drawings (unit: mm).....	3
4.2 The external dimensions of the accompanying transformer(unit: mm).....	4
4.3 Wiring.....	4
5. Indicator Light Explanation.....	6
6. Communication description.....	7
6.1 Communication Protocol.....	7
6.2 MODBUS Communication.....	7
7. Troubleshooting Guidance.....	12
7.1 RS485 communication failure.....	12
7.2 The module doesn' t work and the POW light is off.....	12

1. General

ADW600 multi-circuit power metering module is mainly used for measuring the three-phase active power of low-voltage power grid. It has the advantages of small size, easy installation, and rich functions. The product adopts a modular design, including voltage module, current module, switch(DO) module, temperature measurement and leakage current module, etc. Modules are connected by Ethernet cables and supports multi-module combination. It is suitable for multi-circuit metering scenarios on the low-voltage grid, especially for power renovation needs.

2. Type and Function description

1) ADW600 Multi-circuit power metering module naming rules

ADW600 main module:

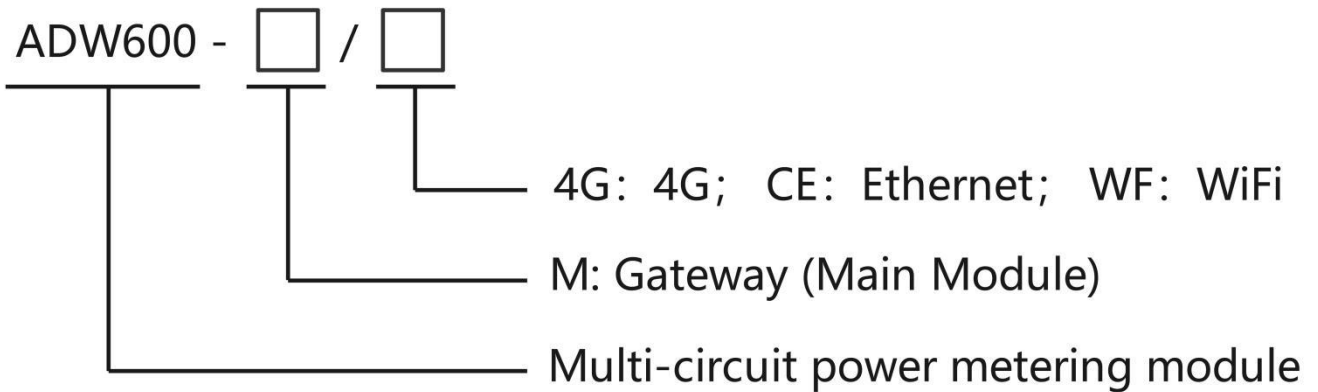

ADW600 sub module:

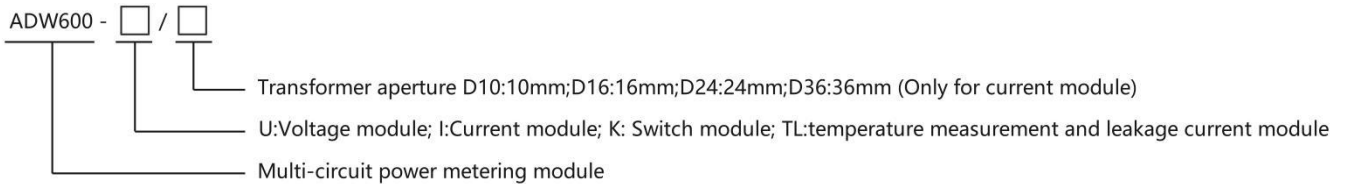

2) ADW600 Functions

Table1 ADW600 Main Function

Model	Function
ADW600-M	Data collection and remote transmission (4G / Ethernet / WIFI)
ADW600-U	Voltage measurement and sampling
ADW600-I	Active power metering (positive and reverse), Quadrant reactive power energy
	Voltage, current, power factor, frequency, active power, reactive power, apparent power
	Total harmonic content, sub-harmonic content (2nd to 31st)
	Pulse Output of active energy
ADW600-K	4DI、2DO
ADW600-TL	12 channels of temperature measurement, 4 channels of residual current measurement

3. Technical parameter

3.1 Electrical Characteristics

Table 2 ADW600 electrical characteristics

ADW600-U	Rated Voltage	3×57.7/100V, 3×220/380V, 3×100V, 3×380V
	Voltage Accuracy	0.5%
	Frequency	45-65Hz
	Power Consumption	<0.5VA (each phase)
ADW600-I	Input Current	D10: 0.03-0.15(6)A, D16: 0.8-2(100)A, D24: 3.2-8(400)A, D36: 4.8-12(600)A
	Accuracy of Active Energy	B Class
	Pulse width of energy	80±20ms
	Active Energy Pulse Constant	D10: 6400imp/kWh, D16: 400imp/kWh, D24: 100imp/kWh, D36: 60imp/kWh
	Power Consumption	<1VA (each phase)
ADW600-K	DI	4-channel passive input, built-in DC12V power supply
	DO	2-channel passive output, capacity AC230V/DC30V, 3A
ADW600-TL	Temperature Measurement	12-channel temperature measurement, accuracy: ±2℃, with 12 temperature measurement leads.
	Residual Current Measurement	4-channel residual current measurement, input range up to 1mA, accuracy 1%, residual current transformer must be purchased separately

3.2 Environmental Conditions

Table 3 ADW600 Environmental Conditions

Temperature Range	Operating temperature	-25℃~55℃
-------------------	-----------------------	----------

	Storage temperature	-40°C~70°C
Humidity		≤95% (without condensation)
Altitude		<2000m

4. Dimension drawings and Installing

4.1 Dimension drawings (unit: mm)

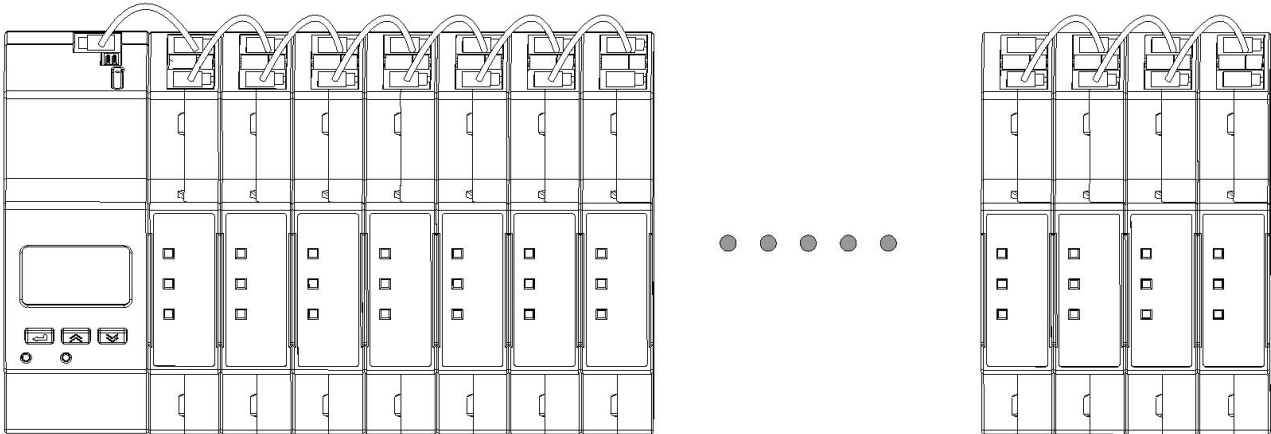

Fig 1 ADW600 effect picture

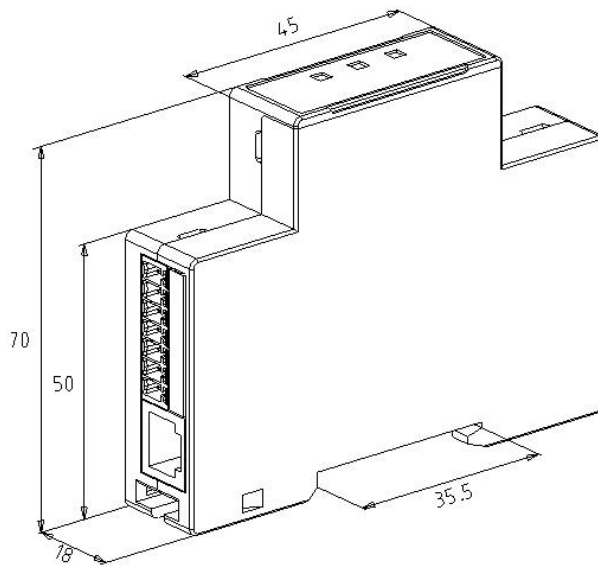

Fig 2 ADW600 dimensional drawing

Note:

1. In the effect picture of ADW600 in Figure 1, the ADW600-M (-4G/-CE/-WF) gateway on the far left must be ordered separately.
2. When connecting the Ethernet cables between different modules, it is necessary to note that BUS-IN is the input interface and BUS-OUT is the output interface. Start from the ADW600-M or the power module and connect them sequentially from left to right. Do not connect in reverse.

4.2 The external dimensions of the accompanying transformer(unit: mm)

Table 4 ADW600-I The external dimensions of the accompanying transformer

Specification: Model	Dimensions (mm)					Pore size (mm)		Tolerance (mm)
	W	H	D	M	N	Φ1	Φ2	
D10: AKH-0.66/K-∅ 10N	27	44	32	25	36	10	9	±1
D16: AKH-0.66/K-∅ 16N	31	50	36	27	42	16	17	
D24: AKH-0.66/K-∅ 24N	39	71	46	36	52	24	23.5	
D36: AKH-0.66/K-∅ 36N	42.5	82	58	40	56	33.5	35	

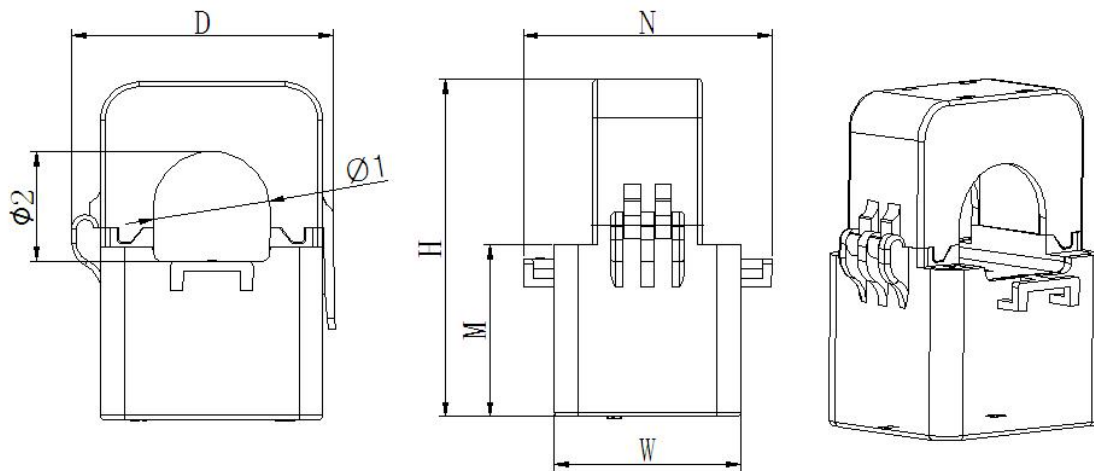

Fig 3 The external dimensions of the accompanying transformer

4.3 Wiring

ADW600 multi-channel metering module is connected by Ethernet cables between each other. BUS-IN is the input interface and BUS-OUT is the output interface. Connect them from the ADW600-M or power module as the starting point and proceed in sequence. Do not connect in reverse.

ADW600-U should connect with the load voltage signal. Refer to the wiring diagram below. Connect the voltage signals of UA, UB, UC, and UN to terminals 11-14 respectively. If a three-phase three-wire connection method is used, connect the voltage signals of UA, UB, and UC to terminal 11-13. Then, short-circuit UB to the UN terminal.

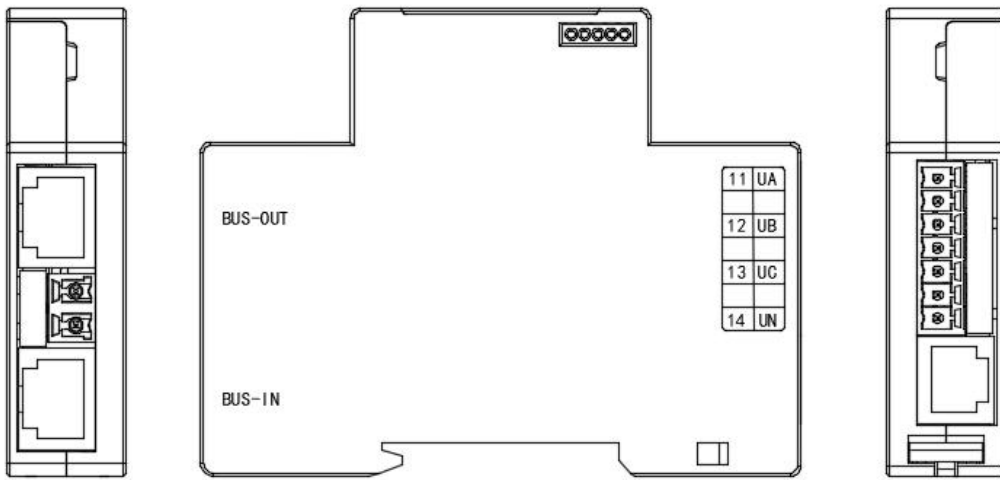

Fig 4 ADW600-U Wiring Diagram

ADW600-I should connect with the load current signal. Refer to the wiring diagram below. The standard transformer is a RJ12 interface that can be inserted into the meter terminals. Simply place the three transformers according to the indicated directions on the load cables.

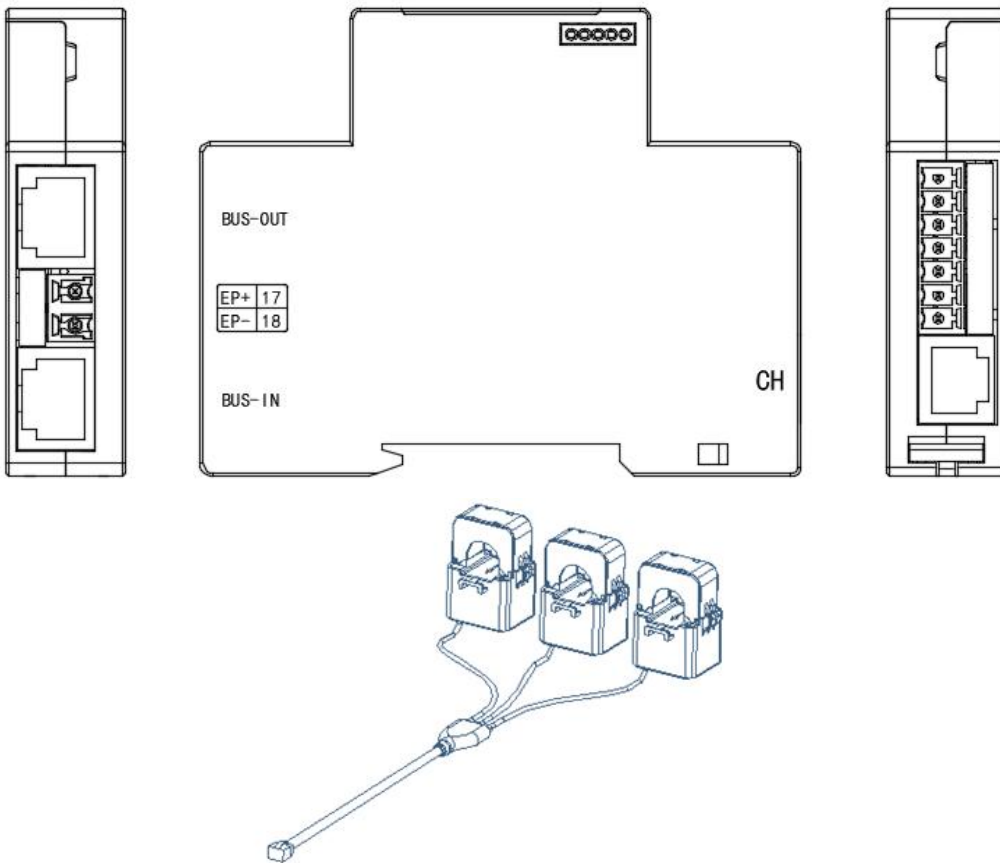

Fig 5 ADW600-I Wiring Diagram

ADW600-K connect with switch input or output signal lines as needed. Please note that the COM port is the common terminal. Refer to the wiring diagram below.

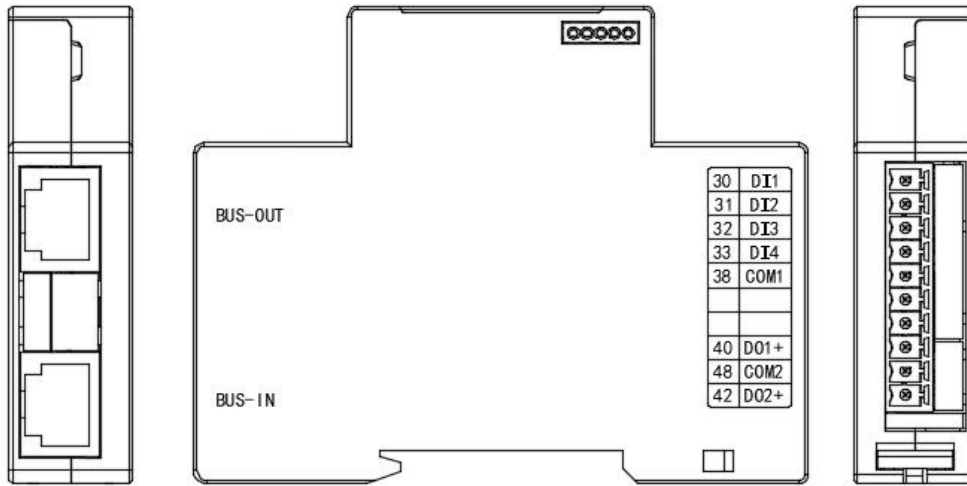

Fig 6 ADW600-K Wiring Diagram

ADW600-TL connects with the temperature measurement signal line or the residual current transformer signal line as needed. Note that the COM port is the common terminal for adjacent measurement circuits. The specific wiring diagram is as follows.

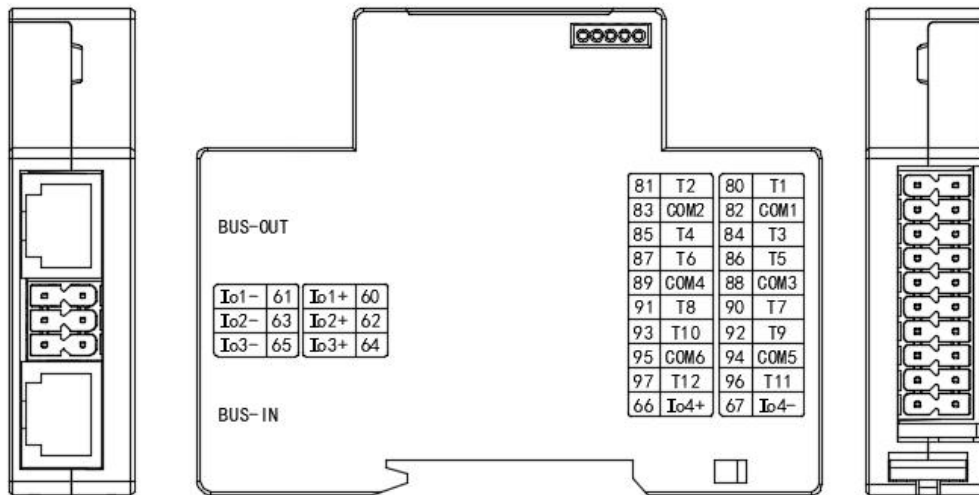



Fig 7 ADW600-TL Wiring Diagram

5. Indicator Light Explanation

The LED indicator lights of ADW600 are described as follows.

Table 5 Indicator Light Explanation

Name of Lights	Explanation
POW	Power indicator light, normally on when working well
RUN	Operation indicator light: normal:green; faulty:red.
ALARM	Alarm indicator light, always on when alarm is triggered
	The pulse indicator light. If the pulse constant is 600, each pulse represents 1/600 kilowatt-hours of electricity.

6. Communication description

6.1 Communication Protocol

This instrument's RS485 interface adopts the MODBUS-RTU protocol. For the specific protocol format, please refer to the relevant protocol standards. No further elaboration is necessary here.

6.2 MODBUS Communication

Based on Modbus protocol, the function code for reading data is 03H, and the function code for writing data is 10H. The specific address tables for each module are as follows:

Table 6 ADW600-U、ADW600-I Register Address Table

start address (hexadecimal)	start address (decimal)	Data item name	Length (Byte)	R/W	Remark
0000H~0002H	0-2	Time & Date (Sec, Min, Hour, Day, Month, Year)			
0003H	3	Device type	2	R	0: Voltage module; 1: Current module; 2: K module, 3: TL module
0004H	4	Reserved			
0005H	5	Communication Address	2	R/W	1-247
0006H	6	Baud Rate	2	R/W	0: 1200bps, 1: 2400bps 2: 4800bps, 3: 9600bps 4: 19200bps, 5: 38400bps
0007H	7	High byte: Stop bit, Low byte: Check method	2	R/W	Low: 0-No parity; 1-Even parity; 2-Odd parity; Hi: 0-1 stop bit; 1-2 stop bit.
0008H~000EH	8-14	Serial Number	2	R/W	14-bit ASCII code
000FH	15	Reserved			
0010H	16	Wire system	2	R/W	0: three-phase four-wire, 1: three-phase three-wire
0011H	17	Voltage ratio	2	R/W	Int
0012H	18	Current ratio	2	R/W	Int
1000H	4096	A phase voltage	2	R	Int Keep one decimal place, unit 0.1V. e.g. voltage data=2200, PT=1; U=U*PT=2200*0.1*1=220.0V
1001H	4097	B phase voltage	2	R	
1002H	4098	C phase voltage	2	R	
1003H	4099	AB line voltage	2	R	
1004H	4100	BC line voltage	2	R	
1005H	4101	CA line voltage	2	R	
The following only ADW600-I supports .					
1006H	4102	A phase current	2	R	Int, unit: 0.01A Keep 2 decimal place e.g. current data=200, CT=10; I=I*CT=200*0.01*10=20A
1007H	4103	B phase current	2	R	
1008H	4104	C phase current	2	R	
1009H	4105	Neutral line current,	2	R	
100AH	4106	A active power	4	R	Signed Int, Keep 3 decimal place , Unit: 0.001kW,
100CH	4108	B active power	4	R	

100EH	4110	C active power	4	R	e.g. data=11720, PT=10, CT=10; active power=data*PT*CT= 11720*0.001*10*10=1172.0kW
1010H	4112	Total active power	4	R	
1012H	4114	A reactive power	4	R	Unit:0.001kVar Ditto
1014H	4116	B reactive power	4	R	
1016H	4118	C reactive power	4	R	
1018H	4120	Total reactive power	4	R	
101AH	4122	A apparent power	4	R	Unit:0.001kVA Ditto
101CH	4124	B apparent power	4	R	
101EH	4126	C apparent power	4	R	
1020H	4128	Total apparent power	4	R	
1022H	4130	A power factor	2	R	Int Keep 3 decimal place e.g. data=999, Power Factor=999*0.001=0.999
1023H	4131	B power factor	2	R	
1024H	4132	C power factor	2	R	
1025H	4133	Total power factor	2	R	
1026H	4134	Frequency	2	R	Int, Keep 2 decimal place e.g. data=5000, Frequency=5000*0.01=50.00Hz
1027H	4135	Reserved			
1028H	4136	A Voltage phase angle	2	R	Unsigned Int, Keep 2 decimal place e.g. data=2011, Angle=2011*0.01=20.11°
1029H	4137	B voltage to A voltage angle	2	R	
102AH	4138	C voltage to A voltage angle	2	R	
102BH	4139	A current to A voltage angle	2	R	
102CH	4140	B current to A voltage angle	2	R	
102DH	4141	C current to A voltage angle	2	R	
102EH	4142	Voltage unbalance	2	R	Unsigned Int, Unit:0.01%, e.g. data=201, Unbalance=201*0.01=2.01%
102FH	4143	Current unbalance	2	R	
1030H	4144	Current total active energy	4	R	Energy are 32bits unsigned Int, Keep 2 decimal place, Unit:0.01kWh, 0.01kVarh, 0.01kVAh e.g. data=120201, PT=10, CT=10; Real energy=data*PT*CT= 120201*0.01*10*10=120201
1032H	4146	Current forward active energy	4	R	
1034H	4148	Current reversing active energy	4	R	
1036H	4150	Current forward reactive energy	4	R	
1038H	4152	Current reversing reactive energy	4	R	
103AH	4154	Apparent power	4	R	
103CH	4156	Current total active F1 energy	4	R	
103EH	4158	Current total active F2 energy	4	R	
1040H	4160	Current total active F3 energy	4	R	
1042H	4162	Current total active F4 energy	4	R	
1044H	4164	Current total active F5 energy	4	R	
1046H	4166	Current total active F6 energy	4	R	
1048H	4168	Current total active F7 energy	4	R	
104AH	4170	Current total active F8 energy	4	R	
104CH	4172	Current forward active F1 energy	4	R	
104EH	4174	Current forward active F2 energy	4	R	
1050H	4176	Current forward active F3 energy	4	R	
1052H	4178	Current forward active F4 energy	4	R	

1054H	4180	Current forward active F5 energy	4	R
1056H	4182	Current forward active F6 energy	4	R
1058H	4184	Current forward active F7 energy	4	R
105AH	4186	Current forward active F8 energy	4	R
105CH	4188	Current reversing active F1 energy	4	R
105EH	4190	Current reversing active F2 energy	4	R
1060H	4192	Current reversing active F3 energy	4	R
1062H	4194	Current reversing active F4 energy	4	R
1064H	4196	Current reversing active F5 energy	4	R
1066H	4198	Current reversing active F6 energy	4	R
1068H	4200	Current reversing active F7 energy	4	R
106AH	4202	Current reversing active F8 energy	4	R
106CH	4204	Current forward reactive F1 energy	4	R
106EH	4206	Current forward reactive F2 energy	4	R
1070H	4208	Current forward reactive F3 energy	4	R
1072H	4210	Current forward reactive F4 energy	4	R
1074H	4212	Current forward reactive F5 energy	4	R
1076H	4214	Current forward reactive F6 energy	4	R
1078H	4216	Current forward reactive F7 energy	4	R
107AH	4218	Current forward reactive F8 energy	4	R
107CH	4220	Current reversing reactive F1 energy	4	R
107EH	4222	Current reversing reactive F2 energy	4	R
1080H	4224	Current reversing reactive F3 energy	4	R
1082H	4226	Current reversing reactive F4 energy	4	R
1084H	4228	Current reversing reactive F5 energy	4	R
1086H	4230	Current reversing reactive F6 energy	4	R
1088H	4232	Current reversing reactive F7 energy	4	R
108AH	4234	Current reversing reactive F8 energy	4	R
108CH	4236	F1 apparent energy	4	R
108EH	4238	F2 apparent energy	4	R
1090H	4240	F3 apparent energy	4	R
1092H	4242	F4 apparent energy	4	R
1094H	4244	F5 apparent energy	4	R
1096H	4246	F6 apparent energy	4	R
1098H	4248	F7 apparent energy	4	R
109AH	4250	F8 apparent energy	4	R
109CH	4252	A phase total active energy	4	R
109EH	4254	A phase forward active energy	4	R
10A0H	4256	A phase reversing active energy	4	R
10A2H	4258	A phase forward reactive energy	4	R
10A4H	4260	A phase reversing reactive energy	4	R
10A6H	4262	B phase total active energy	4	R
10A8H	4264	B phase forward active energy	4	R
10AAH	4266	B phase reversing active energy	4	R
10ACH	4268	B phase forward reactive energy	4	R
10AEH	4270	B phase reversing reactive energy	4	R

10B0H	4272	C phase total active energy	4	R	
10B2H	4274	C phase forward active energy	4	R	
10B4H	4276	C phase reversing active energy	4	R	
10B6H	4278	C phase forward reactive energy	4	R	
10B8H	4280	C phase reversing reactive energy	4	R	
10BAH	4282	Current total reactive energy	4	R	
10BCH	4284	Current first quadrant reactive energy	4	R	
10BEH	4286	Current second quadrant reactive energy	4	R	
10C0H	4288	Current third quadrant reactive energy	4	R	
10C2H	4290	Current fourth quadrant reactive energy	4	R	
10C4H	4292	Current forward active demand	4	R	Unsigned Int, Keep 3 decimal place, refer to power
10C6H	4294	Current reversing active demand	4	R	
10C8H	4296	Current forward reactive demand	4	R	
10CAH	4298	Current reversing reactive demand	4	R	
10CCH	4300	Current apparent power real time demand	4	R	
10CEH	4302	Current A phase current real time demand	2	R	Unsigned Int, Keep 2 decimal place refer to current
10CFH	4303	Current B phase current real time demand	2	R	
10D0H	4304	Current C phase current real time demand	2	R	
10D1H	4305	Reserved			
10D2H	4306	forward active Max demand	4	R	32bits unsigned Int, Keep 3 decimal place, refer to power Occurrence time: The four bytes are in sequence: minute, hour, day, month.
10D4H	4308	Occurrence time	4	R	
10D6H	4310	reversing active Max demand	4	R	
10D8H	4312	Occurrence time	4	R	
10DAH	4314	forward reactive Max demand	4	R	
10DCH	4316	Occurrence time	4	R	
10DEH	4318	reversing reactive Max demand	4	R	
10E0H	4320	Occurrence time	4	R	
10E2H	4322	apparent power Max demand	4	R	
10E4H	4324	Occurrence time	4	R	
10E6H	4326	A phase current Max demand	2	R	16bits unsigned Int, Keep 2 decimal place, refer to current Occurrence time: The four bytes are in sequence: minute, hour, day, month.
10E7H	4327	Occurrence time	4	R	
10E9H	4329	B phase current Max demand	2	R	
10EAH	4330	Occurrence time	4	R	
10ECH	4332	C phase current Max demand	2	R	
10EDH	4333	Occurrence time	4	R	
10EFH	4335	A phase voltage total distortion rate	2	R	Unsigned Int Keep 2 decimal place e. g. data=2425,
10FOH	4336	B phase voltage total distortion rate	2	R	
10F1H	4337	C phase voltage total distortion rate	2	R	

10F2H	4338	A phase current total distortion rate	2	R	total distortion rate=2425*0.01=25.24%
10F3H	4339	B phase current total distortion rate	2	R	
10F4H	4340	C phase current total distortion rate	2	R	
1121H~1152H	4385-4434	A phase voltage sub-harmonic(2-51times)	2	R	Unsigned Int Keep 2 decimal place e. g. data=2425, sub-harmonic=2425*0.01=25.24%
1153H~1184H	4435-4484	B phase voltage sub-harmonic(2-51times)	2	R	
1185H~11B6H	4485-4534	C phase voltage sub-harmonic(2-51times)	2	R	
11B7H~11E8H	4535-4584	A phase current sub-harmonic(2-51times)	2	R	
11E9H~121AH	4585-4634	B phase current sub-harmonic(2-51times)	2	R	
121BH~127EH	4635-4684	C phase current sub-harmonic(2-51times)	2	R	

Table 7 ADW600-K Register Address Table

start address (hexadecimal)	start address (decimal)	Data item name	Length (Byte)	R/W	Remark
0000H~0002H	0-2	Date & Time (Sec, Min, Hour, Day, Month, Year)			
0003H	3	Device type	2	R	2: Switch (DI/DO) module
0004H	4	Reserved			
0005H	5	Communication Address	2	R/W	1-247
0006H	6	Baud Rate	2	R/W	0: 1200bps, 1: 2400bps 2: 4800bps, 3: 9600bps 4: 19200bps, 5: 38400bps
0007H	7	High byte: Stop bit, Low byte: Check method	2	R/W	Low:0-No parity;1-Even parity;2-Odd parity; Hi;0-1 stop bit; 1-2stop bit.
0008H~000EH	8-14	Serial Number	2	R/W	14-bit ASCII code
000FH	15	Reserved			
0010H	16	DI Status	2	R	Bit0-Bit3:DI0-DI4 status
0011H	17	DO 1 Control	2	R/W	0:off, 1:on
0012H	18	DO 2 Control	2	R/W	

Table 8 ADW600-TL Register Address Table

start address (hexadecimal)	start address (decimal)	Data item name	Length (Byte)	R/W	Remark
0000H~0002H	0-2	Date & Time (Sec, Min, Hour, Day, Month, Year)			
0003H	3	Device type	2	R	3: TL module
0004H	4	Reserved			
0005H	5	Communication Address	2	R/W	1-247
0006H	6	Baud Rate	2	R/W	0: 1200bps, 1: 2400bps

					2: 4800bps, 3: 9600bps 4: 19200bps, 5: 38400bps
0007H	7	High byte: Stop bit, Low byte: Check method	2	R/W	Low:0-No parity;1-Even parity;2-Odd parity; Hi;0-1 stop bit; 1-2stop bit.
0008H~000EH	8-14	Serial Number	2	R/W	14-bit ASCII code
000FH	15	Reserved			
1000H	4096	Temperature1	2	R	Signed Int Unit:0.1℃ e. g. Data=425, Temperature=425*0.1=42.5℃
1001H	4097	Temperature2	2	R	
1002H	4098	Temperature3	2	R	
1003H	4099	Temperature4	2	R	
1004H	4100	Temperature5	2	R	
1005H	4101	Temperature6	2	R	
1006H	4102	Temperature7	2	R	
1007H	4103	Temperature8	2	R	
1008H	4104	Temperature9	2	R	
1009H	4105	Temperature10	2	R	
100AH	4106	Temperature11	2	R	
100BH	4107	Temperature12	2	R	
100CH	4108	Leak current1	2	R	Unsigned Int, unit:mA Refer to current
100DH	4109	Leak current2	2	R	
100EH	4110	Leak current3	2	R	
100FH	4111	Leak current4	2	R	

7. Troubleshooting Guidance

7.1 RS485 communication failure

Troubleshooting suggestions: First, please check if the RS485 wiring is loose or if the A and B lines are reversed. Then, pressing the buttons to check if the communication parameters are correct, such as the address, baud rate, check bit, etc.

7.2 The module doesn't work and the POW light is off

Troubleshooting suggestions: Check if the Ethernet cables between the modules are properly connected. Verify if BUS-IN and BUS-OUT are connected correctly. You may swap the Ethernet cables of the working module to check if the Ethernet cable is faulty.

